

How to Adjust Your Freedom Task Chair

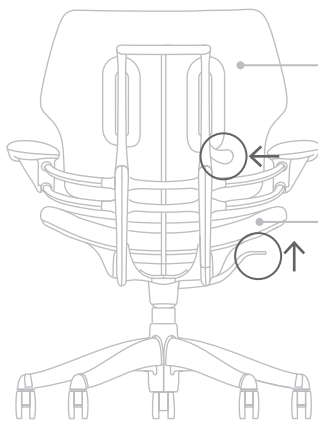

Backrest/Lumbar Support Height

While seated, grasp backrest with both hands on lower corner. Squeeze handle at right with fingertips and move backrest to most comfortable height.

Seat Height

Lift up on lever under right side of seat cushion and position chair to a comfortable height, with your thighs parallel to the floor and your feet fully supported by the floor or footrest. Release lever.

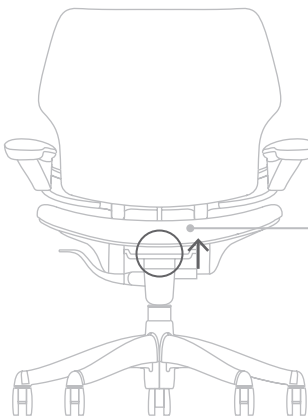

Seat Depth

Lift up on lever under forward edge of seat and slide seat to a position such that when you are sitting with your back fully against the backrest, there are 2-4 inches of clearance between the front edge of the seat and the back of your knee. Release lever.

Synchronous Armrests

Freedom's armrests can be adjusted synchronously, without touching any release buttons, and stay with you during recline to always keep your body in supported balance.



To Raise

Gently pull upward on the armrests and raise to desired position. They will automatically lock in place when released.



To Lower

Place hand on armrest, as pictured, rotate wrist toward you to disengage, and lower to desired position. The armrests will automatically lock in place when released.



To Rotate Sideways

(optional feature)

Push the inside of the armrest away from the body in a lateral motion, allowing for a change in position within a 35" arc. The armrest will automatically remain in the position you last put it in, without the use of a button.